

GD CLasses Solutions to IIT-JEE-2010

CODE

3

PAPER 1

Time: 3 Hours

Please read the instructions carefully. You are allotted 5 minutes specifically for this purpose.

INSTRUCTIONS

A. General:

1. This Question Paper contains 32 pages having 84 questions.
2. The **question paper** CODE is printed on the right hand top corner of this sheet and also on the back page (page no. 32) of this booklet.
3. No additional sheets will be provided for rough work.
4. Blank papers, clipboards, log tables, slide rules, calculators, cellular phones, pagers and electronic gadgets in any form are not allowed.
5. The answer sheet, a machine-gradable Objective Response Sheet (**ORS**), is provided separately.
6. Do not Tamper / mutilate the ORS or this booklet.
7. Do not break the seals of the question – paper booklet before instructed to do so by the invigilators.

B. Filling the bottom-half of the ORS:

8. The ORS has CODE printed on its lower and upper Parts.
9. Make sure the CODE on the **ORS** is the same as that on this booklet. **If the Codes do not match, ask for a change of the Booklet.**
10. Write your Registration No., Name and Name of centre and sign with pen in appropriate boxes. **Do not write these any where else.**
11. Darken the appropriate bubbles below your registration number with **HB Pencil**.

C. Question paper format and Marking scheme:

12. The question paper consists of **3 parts** (Chemistry, Mathematics and Physics). Each part consists of four Sections.
13. For each question in **Section I**, you will be **awarded 3 marks** if you darken only the bubble corresponding to the correct answer and zero mark if no bubbles are darkened. In all other cases, **minus one (–1) mark** will be awarded.
14. For each question in **Section II**, you will be awarded **3 marks** if you darken only the bubble corresponding to the correct answer and zero mark if no bubbles are darkened. **Partial marks** will be awarded for partially correct answers. No negative marks will be awarded in this Section.
15. For each question in **Section III**, you will be awarded 3 marks if you darken only the bubble corresponding to the correct answer and zero mark if no bubbles are darkened. In all other cases, **minus one (–1) mark** will be awarded.
16. For each question in **Section IV**, you will be awarded **3 marks** if you darken the bubble corresponding to the correct answer and zero mark if no bubble is darkened. No negative marks will be awarded for in this Section

Write your name, registration number and sign in the space provided on the back page of this booklet.

Useful Data

Atomic Numbers: Be 4; C 6; N 7; O 8; Al 13; Si 14; Cr24; Fe 26; Zn 30; Br 35.					
1 amu	=	1.66×10^{-27} kg	R	=	0.082 L-atm K ⁻¹ mol ⁻¹
h	=	6.626×10^{-34} J s	N _A	=	6.022×10^{23}
m _e	=	9.1×10^{-31} kg	e	=	1.6×10^{-19} C
c	=	3.0×10^8 m s ⁻¹	F	=	96500 C mol ⁻¹
R _H	=	2.18×10^{-18} J	4πϵ ₀	=	1.11×10^{-10} J ⁻¹ C ² m ⁻¹

IITJEE 2010 PAPER-1 [Code – 3]

PART - I: CHEMISTRY

SECTION – I (Single Correct Choice Type)

This Section contains **8 multiple choice questions**. Each question has four choices A), B), C) and D) out of which **ONLY ONE** is correct.

1. The synthesis of 3-octyne is achieved by adding a bromoalkane into a mixture of sodium amide and an alkyne. The bromoalkane and alkyne respectively are
- A) $\text{BrCH}_2\text{CH}_2\text{CH}_2\text{CH}_2\text{CH}_3$ and $\text{CH}_3\text{CH}_2\text{C}\equiv\text{CH}$ B) $\text{BrCH}_2\text{CH}_2\text{CH}_3$ and $\text{CH}_3\text{CH}_2\text{CH}_2\text{C}\equiv\text{CH}$
 C) $\text{BrCH}_2\text{CH}_2\text{CH}_2\text{CH}_2\text{CH}_3$ and $\text{CH}_3\text{C}\equiv\text{CH}$ D) $\text{BrCH}_2\text{CH}_2\text{CH}_2\text{CH}_3$ and $\text{CH}_3\text{CH}_2\text{C}\equiv\text{CH}$

Sol. (D)

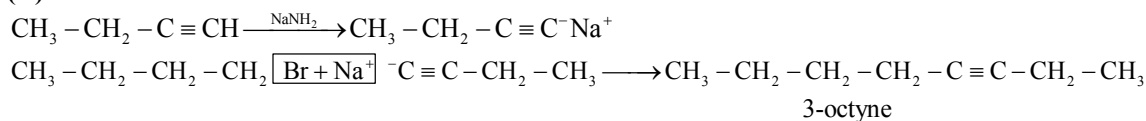

2. The correct statement about the following disaccharide is

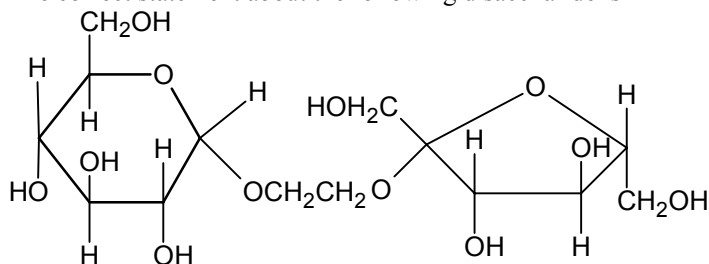

- A) Ring (a) is pyranose with α - glycosidic link
 B) Ring (a) is furanose with α - glycosidic link
 C) Ring (b) is furanose with α - glycosidic link
 D) Ring (b) is pyranose with β - glycosidic link

Ans. (A)

3. In the reaction $\xrightarrow{\text{HBr}}$ the products are

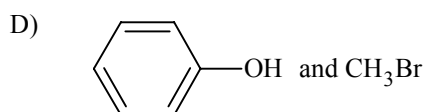
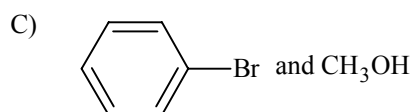
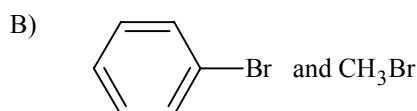
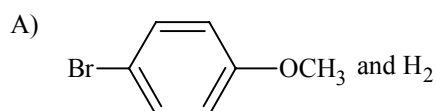

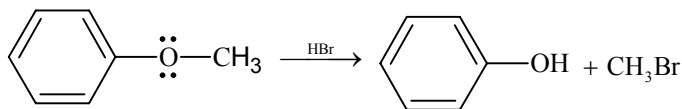
Sol. (D)

4. Plots showing the variation of the rate constant (k) with temperature (T) are given below. The plot that follows Arrhenius equation is

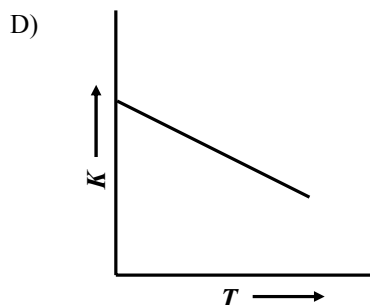
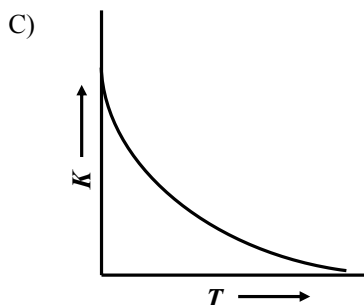
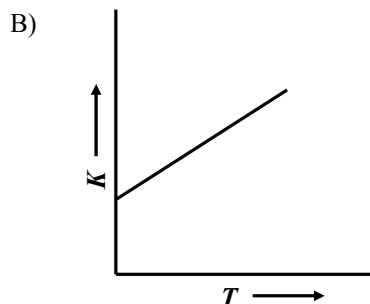
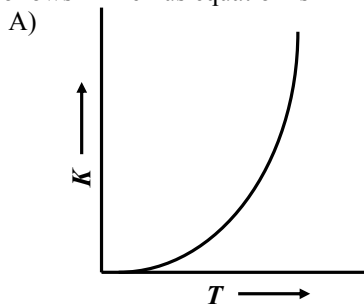
**Sol. (A)**

$$k = Ae^{-E_a/RT}$$

As $T \uparrow$; $k \uparrow$ exponentially.

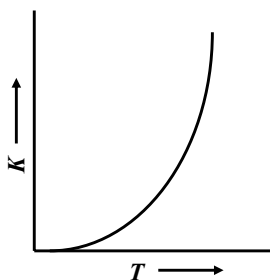

5. The species which by definition has ZERO standard molar enthalpy of formation at 298 K is

- | | |
|-----------------------------|----------------------|
| A) Br_2 (g) | B) Cl_2 (g) |
| C) H_2O (g) | D) CH_4 (g) |

Sol. (B)

Cl_2 is gas at 298 K while Br_2 is a liquid.

6. The bond energy (in kcal mol^{-1}) of a C – C single bond is approximately

- | | |
|--------|---------|
| A) 1 | B) 10 |
| C) 100 | D) 1000 |

Ans. (C)

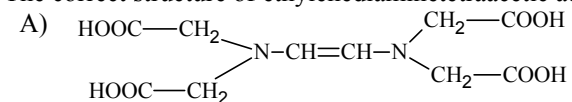
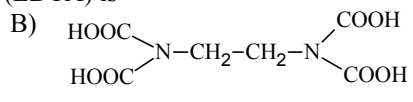
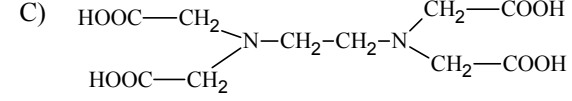
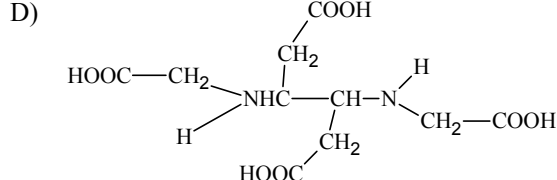
7. The correct structure of ethylenediaminetetraacetic acid (EDTA) is
- A)  B) 
- C)  D) 

Ans. (C)

8. The ionization isomer of $[\text{Cr}(\text{H}_2\text{O})_4\text{Cl}(\text{NO}_2)]\text{Cl}$ is
- A) $[\text{Cr}(\text{H}_2\text{O})_4(\text{O}_2\text{N})\text{Cl}_2]$ B) $[\text{Cr}(\text{H}_2\text{O})_4\text{Cl}_2](\text{NO}_2)$
 C) $[\text{Cr}(\text{H}_2\text{O})_4\text{Cl}(\text{ONO})\text{Cl}]$ D) $[\text{Cr}(\text{H}_2\text{O})_4\text{Cl}_2(\text{NO}_2)]\text{H}_2\text{O}$

Sol. (B)

Cl^- is replaced by NO_2^- in ionization sphere.

SECTION – II (Multiple Correct Choice Type)

This section contains **5 multiple choice questions**. Each question has four choices A), B), C) and D) out of which **ONE OR MORE** may be correct.

9. In the Newman projection for 2,2-dimethylbutane

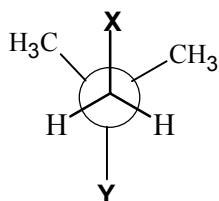

X and Y can respectively be

- A) H and H B) H and C_2H_5
 C) C_2H_5 and H D) CH_3 and CH_3

Sol. (B, D)

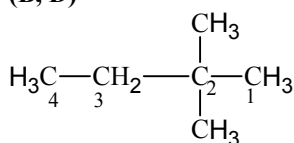

On $\text{C}_2 - \text{C}_3$ bond axis

X = CH_3

Y = CH_3

On $\text{C}_1 - \text{C}_2$ bond axis

X = H

Y = C_2H_5

10. Aqueous solutions of HNO_3 , KOH , CH_3COOH , and CH_3COONa of identical concentrations are provided. The pair (s) of solutions which form a buffer upon mixing is(are)
- A) HNO_3 and CH_3COOH B) KOH and CH_3COONa
 C) HNO_3 and CH_3COONa D) CH_3COOH and CH_3COONa

Sol. (C, D)

In option (C), if HNO_3 is present in limiting amount then this mixture will be a buffer. And the mixture given in option (D), contains a weak acid (CH_3COOH) and its salt with strong base NaOH , i.e. CH_3COONa .

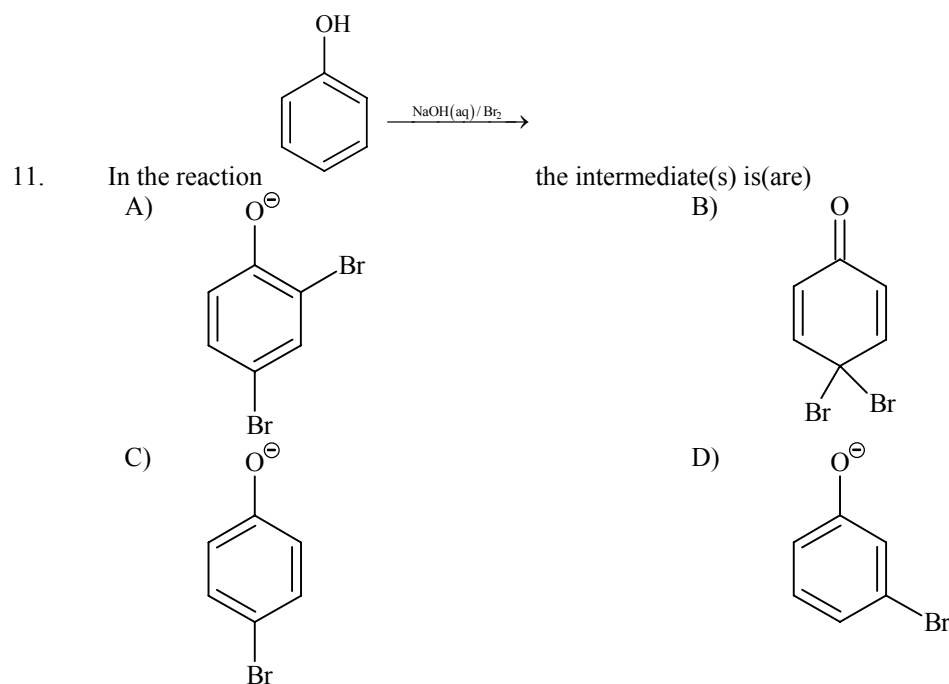

Sol. (A, B, C)

Phenoxide ion is para* and ortho directing. (* preferably)

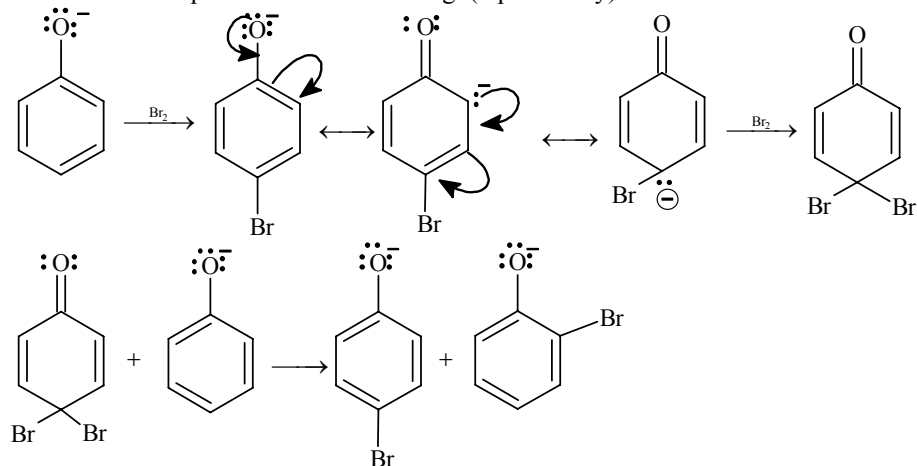

12. The reagent(s) used for softening the temporary hardness of water is(are)
- A) $\text{Ca}_3(\text{PO}_4)_2$ B) $\text{Ca}(\text{OH})_2$
 C) Na_2CO_3 D) NaOCl

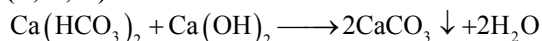
Sol. (B, C, D)

[Clarke's method]

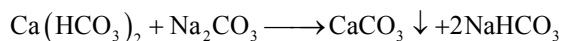
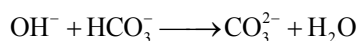
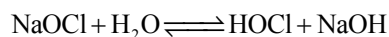

13. Among the following, the intensive property is (properties are)
- | | |
|-----------------------|------------------------|
| A) molar conductivity | B) electromotive force |
| C) resistance | D) heat capacity |

Sol. (A, B)

Resistance and heat capacity are mass dependent properties, hence extensive.

SECTION-III (Paragraph Type)

This section contains **2 paragraphs**. Based upon the first paragraph 2 multiple choice questions and based upon the second paragraph **3 multiple choice questions** have to be answered. Each of these questions has four choices A), B), C) and D) out of **WHICH ONLY ONE CORRECT**.

Paragraph for Question Nos. 14 to 15

The concentration of potassium ions inside a biological cell is at least twenty times higher than the outside. The resulting potential difference across the cell is important in several processes such as transmission of nerve impulses and maintaining the ion balance. A simple model for such a concentration cell involving a metal M is:

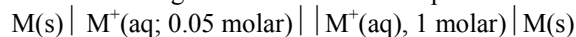
For the above electrolytic cell the magnitude of the cell potential $|E_{\text{cell}}| = 70 \text{ mV}$.

14. For the above cell
- | | |
|--|--|
| A) $E_{\text{cell}} < 0; \Delta G > 0$ | B) $E_{\text{cell}} > 0; \Delta G < 0$ |
| C) $E_{\text{cell}} < 0; \Delta G^\circ > 0$ | D) $E_{\text{cell}} > 0; \Delta G^\circ > 0$ |

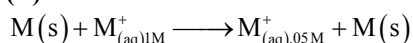
Sol. (B)

According to Nernst equation ,

$$E_{\text{cell}} = 0 - \frac{2.303RT}{F} \log \frac{\text{M}_{0.05\text{M}}^+}{\text{M}_{1\text{M}}^+}$$

$$= 0 - \frac{2.303RT}{F} \log(5 \times 10^{-2})$$

= +ve

Hence, $|E_{\text{cell}}| = E_{\text{cell}} = 0.70 \text{ V}$ and $\Delta G < 0$ for the feasibility of the reaction.

15. If the 0.05 molar solution of M^+ is replaced by 0.0025 molar M^+ solution, then the magnitude of the cell potential would be
- | | |
|-----------|-----------|
| A) 35 mV | B) 70 mV |
| C) 140 mV | D) 700 mV |

Sol. (C)

$$\text{From above equation } \frac{2.303RT}{F} = 0.0538$$

$$\text{So, } E_{\text{cell}} = E_{\text{cell}}^{\circ} - \frac{0.0538}{1} \log 0.0025$$

$$= 0 - \frac{0.0538}{1} \log 0.0025$$

$$\approx 0.13988 \text{ V}$$

$$\approx 140 \text{ mV}$$

Paragraph for Question Nos. 16 to 18

Copper is the most noble of the first row transition metals and occurs in small deposits in several countries. Ores of copper include chalcantite ($\text{CuSO}_4 \cdot 5\text{H}_2\text{O}$), atacamite ($\text{Cu}_2\text{Cl}(\text{OH})_3$), cuprite (Cu_2O), copper glance (Cu_2S) and malachite ($\text{Cu}_2(\text{OH})_2\text{CO}_3$). However, 80% of the world copper production comes from the ore of chalcopyrite (CuFeS_2). The extraction of copper from chalcopyrite involves partial roasting, removal of iron and self-reduction.

16. Partial roasting of chalcopyrite produces

- A) Cu_2S and FeO
C) CuS and Fe_2O_3

- B) Cu_2O and FeO
D) Cu_2O and Fe_2O_3

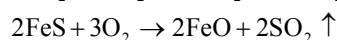
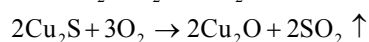
Sol. (B)

17. Iron is removed from chalcopyrite as

- A) FeO
C) Fe_2O_3

- B) FeS
D) FeSiO_3

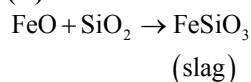
Sol. (D)

18. In self-reduction, the reducing species is

- A) S
C) S^{2-}

- B) O^{2-}
D) SO_2

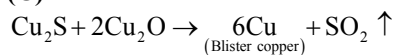
Sol. (C)

$\text{S}^{2-} \rightarrow \text{S}^{4+}$ is oxidation, i.e., S^{2-} is reducing agent.

SECTION-IV (Integer Type)

This section contains **TEN** questions. The answer to each question is a single digit integer ranging from 0 to 9. The correct digit below the question number in the **ORS** is to be bubbled.

19. A student performs a titration with different burettes and finds titre values of 25.2 mL, 25.25 mL and 25.0 mL. The number of significant figures in the average titre value is

Ans. 3

20. The concentration of R in the reaction $R \rightarrow P$ was measured as a function of time and the following data is obtained:

[R] (molar)	1.0	0.75	0.40	0.10
t (min.)	0.0	0.05	0.12	0.18

The order of the reaction is

Sol. 0

From two data, (for zero order kinetics)

$$K_1 = \frac{x}{t} = \frac{0.25}{0.05} = 5$$

$$K_{II} = \frac{x}{t} = \frac{0.60}{0.12} = 5$$

21. The number of neutrons emitted when ${}_{92}^{235}\text{U}$ undergoes controlled nuclear fission to ${}_{54}^{142}\text{Xe}$ and ${}_{38}^{90}\text{Sr}$ is

Sol. 3

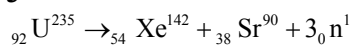

22. The total number of basic groups in the following form of lysine is

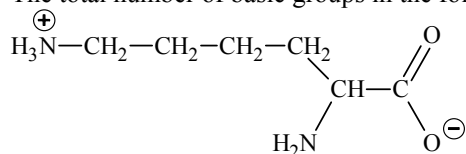

Sol. 2

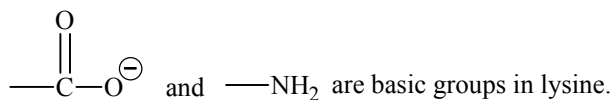

23. The total number of cyclic isomers possible for a hydrocarbon with the molecular formula C_4H_6 is

Sol. 5

In C_4H_6 , possible cyclic isomers are

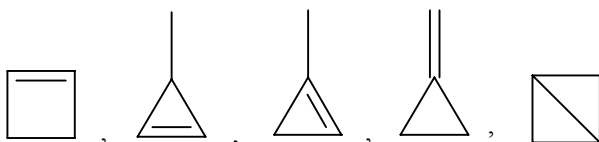

24. In the scheme given below, the total number of intra molecular aldol condensation products formed from 'Y' is

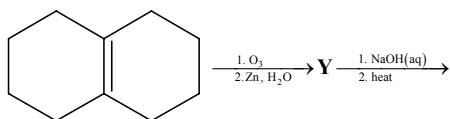

Sol. 1

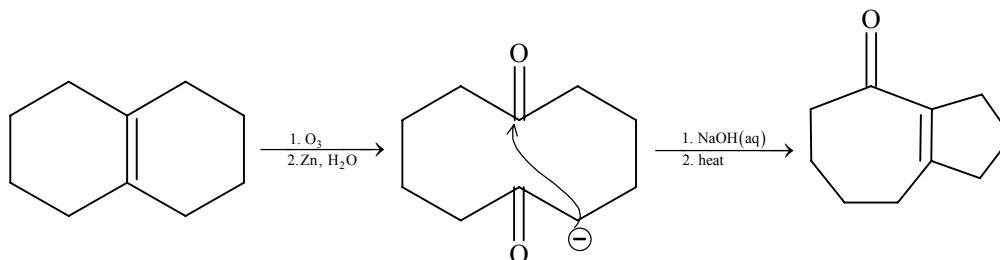

25. Amongst the following, the total number of compound soluble in aqueous NaOH is

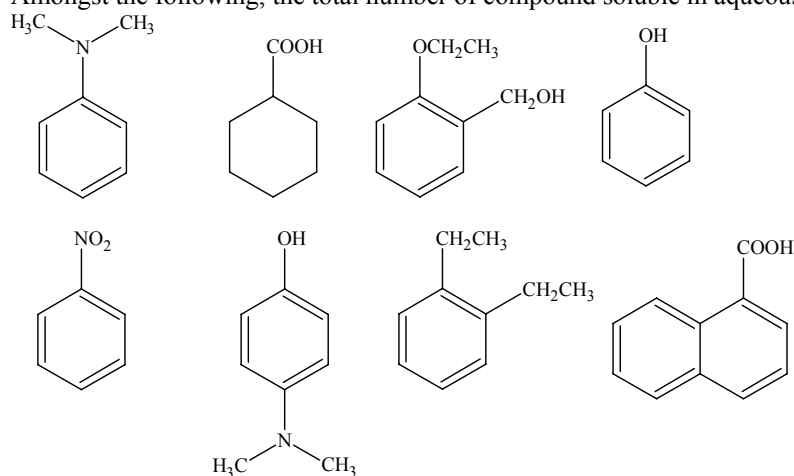

Sol. 4

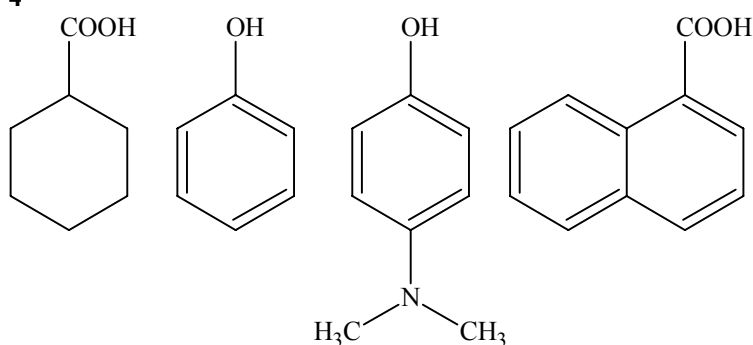

These four are soluble in aqueous NaOH.

26. Amongst the following, the total number of compounds whose aqueous solution turns red litmus paper blue is



Sol. 3

KCN, K₂CO₃, LiCN are basic in nature and their aqueous solution turns red litmus paper blue.

27. Based on VSEPR theory, the number of 90 degree F–Br–F angles in BrF₅ is

Sol. 0

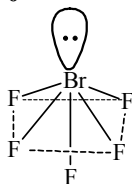

All four planar bonds (F–Br–F) will reduce from 90° to 84.8° after $\ell p - bp$ repulsion.

28. The value of n in the molecular formula Be_nAl₂Si₆O₁₈ is

Sol. 3

Be₃Al₂Si₆O₁₈ (Beryl)
(according to charge balance in a molecule)

$$2n + 6 + 24 - 36 = 0$$

$$n = 3$$

PART - II: MATHEMATICS

SECTION – I (Single Correct Choice Type)

This Section contains **8 multiple choice questions**. Each question has four choices A), B), C) and D) out of which **ONLY ONE** is correct.

29. Let ω be a complex cube root of unity with $\omega \neq 1$. A fair die is thrown three times. If r_1, r_2 and r_3 are the numbers obtained on the die, then the probability that $\omega^{r_1} + \omega^{r_2} + \omega^{r_3} = 0$ is

- (A) $\frac{1}{18}$ (B) $\frac{1}{9}$
 (C) $\frac{2}{9}$ (D) $\frac{1}{36}$

Sol. (C)

$$r_1, r_2, r_3 \in \{1, 2, 3, 4, 5, 6\}$$

$$r_1, r_2, r_3 \text{ are of the form } 3k, 3k+1, 3k+2$$

$$\text{Required probability} = \frac{3! \times {}^2C_1 \times {}^2C_1 \times {}^2C_1}{6 \times 6 \times 6} = \frac{6 \times 8}{216} = \frac{2}{9}.$$

30. Let P, Q, R and S be the points on the plane with position vectors $-2\hat{i} - \hat{j}$, $4\hat{i}$, $3\hat{i} + 3\hat{j}$ and $-3\hat{i} + 2\hat{j}$ respectively. The quadrilateral PQRS must be a

- (A) parallelogram, which is neither a rhombus nor a rectangle
 (B) square
 (C) rectangle, but not a square
 (D) rhombus, but not a square

Sol. (A)

Evaluating midpoint of PR and QS which

$$\text{gives } M \equiv \left[\frac{\hat{i}}{2} + \hat{j} \right], \text{ same for both.}$$

$$\overline{PQ} = \overline{SR} = 6\hat{i} + \hat{j}$$

$$\overline{PS} = \overline{QR} = -\hat{i} + 3\hat{j}$$

$$\Rightarrow \overline{PQ} \cdot \overline{PS} \neq 0$$

$$\overline{PQ} \parallel \overline{SR}, \overline{PS} \parallel \overline{QR} \text{ and } |\overline{PQ}| = |\overline{SR}|, |\overline{PS}| = |\overline{QR}|$$

Hence, PQRS is a parallelogram but not rhombus or rectangle.

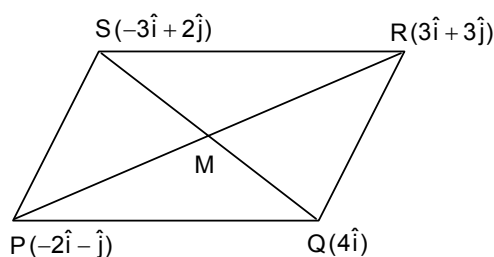

31. The number of 3×3 matrices A whose entries are either 0 or 1 and for which the system $A \begin{bmatrix} x \\ y \\ z \end{bmatrix} = \begin{bmatrix} 1 \\ 0 \\ 0 \end{bmatrix}$ has

exactly two distinct solutions, is

- (A) 0 (B) $2^9 - 1$
 (C) 168 (D) 2

Sol. (A)

Three planes cannot intersect at two distinct points.

32. The value of $\lim_{x \rightarrow 0} \frac{1}{x^3} \int_0^x \frac{t \ln(1+t)}{t^4+4} dt$ is

(A) 0

(B) $\frac{1}{12}$ (C) $\frac{1}{24}$ (D) $\frac{1}{64}$

Sol. (B)

$$\begin{aligned} \lim_{x \rightarrow 0} \frac{1}{x^3} \int_0^x \frac{t \ln(1+t)}{t^4+4} dt &= \lim_{x \rightarrow 0} \frac{x \ln(1+x)}{(x^4+4)3x^2} \\ &= \lim_{x \rightarrow 0} \frac{1}{3} \frac{\ln(1+x)}{x(x^4+4)} = \frac{1}{12} \end{aligned}$$

33. Let p and q be real numbers such that $p \neq 0$, $p^3 \neq q$ and $p^3 \neq -q$. If α and β are nonzero complex numbers satisfying $\alpha + \beta = -p$ and $\alpha^3 + \beta^3 = q$, then a quadratic equation having $\frac{\alpha}{\beta}$ and $\frac{\beta}{\alpha}$ as its roots is

(A) $(p^3+q)x^2 - (p^3+2q)x + (p^3+q) = 0$

(B) $(p^3+q)x^2 - (p^3-2q)x + (p^3+q) = 0$

(C) $(p^3-q)x^2 - (5p^3-2q)x + (p^3-q) = 0$

(D) $(p^3-q)x^2 - (5p^3+2q)x + (p^3-q) = 0$

Sol. (B)

$$\alpha^3 + \beta^3 = q$$

$$\Rightarrow (\alpha + \beta)^3 - 3\alpha\beta(\alpha + \beta) = q$$

$$\Rightarrow -p^3 + 3p\alpha\beta = q \Rightarrow \alpha\beta = \frac{q+p^3}{3p}$$

$$x^2 - \left(\frac{\alpha}{\beta} + \frac{\beta}{\alpha} \right) x + \frac{\alpha}{\beta} \cdot \frac{\beta}{\alpha} = 0$$

$$x^2 - \frac{(\alpha^2 + \beta^2)}{\alpha\beta} x + 1 = 0$$

$$\Rightarrow x^2 - \left(\frac{(\alpha + \beta)^2 - 2\alpha\beta}{\alpha\beta} \right) x + 1 = 0$$

$$\Rightarrow x^2 - \frac{p^2 - 2\left(\frac{p^3+q}{3p}\right)}{\frac{p^3+q}{3p}} x + 1 = 0$$

$$\Rightarrow (p^3+q)x^2 - (3p^3-2p^3-2q)x + (p^3+q) = 0$$

$$\Rightarrow (p^3+q)x^2 - (p^3-2q)x + (p^3+q) = 0.$$

34. Let f , g and h be real-valued functions defined on the interval $[0, 1]$ by $f(x) = e^{x^2} + e^{-x^2}$, $g(x) = xe^{x^2} + e^{-x^2}$ and $h(x) = x^2e^{x^2} + e^{-x^2}$. If a , b and c denote, respectively, the absolute maximum of f , g and h on $[0, 1]$, then

(A) $a = b$ and $c \neq b$ (B) $a = c$ and $a \neq b$ (C) $a \neq b$ and $c \neq b$ (D) $a = b = c$

Sol. (D)

$$f(x) = e^{x^2} + e^{-x^2} \Rightarrow f'(x) = 2x(e^{x^2} - e^{-x^2}) \geq 0 \quad \forall x \in [0, 1]$$

Clearly for $0 \leq x \leq 1$ $f(x) \geq g(x) \geq h(x)$

$$\therefore f(1) = g(1) = h(1) = e + \frac{1}{e} \text{ and } f(1) \text{ is the greatest}$$

$$\therefore a = b = c = e + \frac{1}{e} \Rightarrow a = b = c.$$

35. If the angles A, B and C of a triangle are in an arithmetic progression and if a, b and c denote the lengths of the sides opposite to A, B and C respectively, then the value of the expression $\frac{a}{c} \sin 2C + \frac{c}{a} \sin 2A$ is

(A) $\frac{1}{2}$

(B) $\frac{\sqrt{3}}{2}$

(C) 1

(D) $\sqrt{3}$

Sol. (D)

$$B = 60^\circ$$

$$\therefore \frac{a}{c} \sin 2C + \frac{c}{a} \sin 2A = 2 \sin A \cos C + 2 \sin C \cos A$$

$$= 2 \sin(A + C) = 2 \sin B = 2 \times \frac{\sqrt{3}}{2} = \sqrt{3}.$$

36. Equation of the plane containing the straight line $\frac{x}{2} = \frac{y}{3} = \frac{z}{4}$ and perpendicular to the plane containing the

straight lines $\frac{x}{3} = \frac{y}{4} = \frac{z}{2}$ and $\frac{x}{4} = \frac{y}{2} = \frac{z}{3}$ is

(A) $x + 2y - 2z = 0$

(B) $3x + 2y - 2z = 0$

(C) $x - 2y + z = 0$

(D) $5x + 2y - 4z = 0$

Sol. (C)

Plane 1: $ax + by + cz = 0$ contains line $\frac{x}{2} = \frac{y}{3} = \frac{z}{4}$

$$\therefore 2a + 3b + 4c = 0 \quad \dots(i)$$

Plane 2: $a'x + b'y + c'z = 0$ is perpendicular to plane containing lines $\frac{x}{3} = \frac{y}{4} = \frac{z}{2}$ and $\frac{x}{4} = \frac{y}{2} = \frac{z}{3}$

$$\therefore 3a' + 4b' + 2c' = 0 \text{ and } 4a' + 2b' + 3c' = 0$$

$$\Rightarrow \frac{a'}{12-4} = \frac{b'}{8-9} = \frac{c'}{6-16}$$

$$\Rightarrow 8a - b - 10c = 0 \quad \dots(ii)$$

From (i) and (ii)

$$\frac{a}{-30+4} = \frac{b}{32+20} = \frac{c}{-2-24}$$

$$\Rightarrow \text{Equation of plane } x - 2y + z = 0.$$

SECTION – II (Multiple Correct Choice Type)

This section contains **5 multiple choice questions**. Each question has four choices A), B), C) and D) out of which **ONE OR MORE** may be correct.

37. Let z_1 and z_2 be two distinct complex numbers and let $z = (1 - t)z_1 + tz_2$ for some real number t with $0 < t < 1$. If $\text{Arg}(w)$ denotes the principal argument of a non-zero complex number w , then
- (A) $|z - z_1| + |z - z_2| = |z_1 - z_2|$ (B) $\text{Arg}(z - z_1) = \text{Arg}(z - z_2)$
- (C) $\begin{vmatrix} z - z_1 & \bar{z} - \bar{z}_1 \\ z_2 - z_1 & \bar{z}_2 - \bar{z}_1 \end{vmatrix} = 0$ (D) $\text{Arg}(z - z_1) = \text{Arg}(z_2 - z_1)$

Sol. (A), (C), (D)

Given $z = (1 - t)z_1 + tz_2$

$$\Rightarrow \frac{z - z_1}{z_2 - z_1} = t \Rightarrow \arg\left(\frac{z - z_1}{z_2 - z_1}\right) = 0 \quad \dots (1)$$

$$\Rightarrow \arg(z - z_1) = \arg(z_2 - z_1)$$

$$\frac{z - z_1}{z_2 - z_1} = \frac{\bar{z} - \bar{z}_1}{\bar{z}_2 - \bar{z}_1}$$

$$\begin{vmatrix} z - z_1 & \bar{z} - \bar{z}_1 \\ z_2 - z_1 & \bar{z}_2 - \bar{z}_1 \end{vmatrix} = 0$$

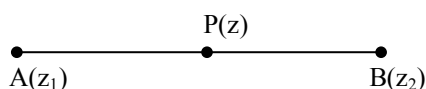

$$AP + PB = AB$$

$$\Rightarrow |z - z_1| + |z - z_2| = |z_1 - z_2|.$$

38. The value(s) of $\int_0^1 \frac{x^4(1-x)^4}{1+x^2} dx$ is (are)

(A) $\frac{22}{7} - \pi$

(B) $\frac{2}{105}$

(C) 0

(D) $\frac{71}{15} - \frac{3\pi}{2}$

Sol. (A)

$$\int_0^1 \frac{x^4(1-x)^4}{1+x^2} dx$$

$$= \int_0^1 \left(x^6 - 4x^5 + 5x^4 - 4x^2 + 4 - \frac{4}{1+x^2} \right) dx$$

$$= \left[\frac{x^7}{7} - \frac{2x^6}{3} + x^5 - \frac{4x^3}{3} + 4x \right]_0^1 - \pi$$

$$= \frac{1}{7} - \frac{2}{3} + 1 - \frac{4}{3} + 4 - \pi = \frac{22}{7} - \pi$$

39. Let ABC be a triangle such that $\angle ACB = \frac{\pi}{6}$ and let a, b and c denote the lengths of the sides opposite to A, B and C respectively. The value(s) of x for which $a = x^2 + x + 1$, $b = x^2 - 1$ and $c = 2x + 1$ is (are)
- (A) $-(2 + \sqrt{3})$ (B) $1 + \sqrt{3}$
 (C) $2 + \sqrt{3}$ (D) $4\sqrt{3}$

Sol. (B)

Using cosine rule for $\angle C$

$$\frac{\sqrt{3}}{2} = \frac{(x^2 + x + 1)^2 + (x^2 - 1)^2 - (2x + 1)^2}{2(x^2 + x + 1)(x^2 - 1)}$$

$$\Rightarrow \sqrt{3} = \frac{2x^2 + 2x - 1}{x^2 + x + 1}$$

$$\Rightarrow (\sqrt{3} - 2)x^2 + (\sqrt{3} - 2)x + (\sqrt{3} + 1) = 0$$

$$\Rightarrow x = \frac{(2 - \sqrt{3}) \pm \sqrt{3}}{2(\sqrt{3} - 2)}$$

$$\Rightarrow x = -(2 + \sqrt{3}), 1 + \sqrt{3} \Rightarrow x = 1 + \sqrt{3} \text{ as } (x > 0).$$

40. Let A and B be two distinct points on the parabola $y^2 = 4x$. If the axis of the parabola touches a circle of radius r having AB as its diameter, then the slope of the line joining A and B can be

- (A) $-\frac{1}{r}$ (B) $\frac{1}{r}$
 (C) $\frac{2}{r}$ (D) $-\frac{2}{r}$

Sol. (C), (D)

$$A = (t_1^2, 2t_1), B = (t_2^2, 2t_2)$$

$$\text{Centre} = \left[\frac{t_1^2 + t_2^2}{2}, (t_1 + t_2) \right]$$

$$t_1 + t_2 = \pm r$$

$$m = \frac{2(t_1 - t_2)}{t_1^2 - t_2^2} = \frac{2}{t_1 + t_2} = \pm \frac{2}{r}$$

41. Let f be a real-valued function defined on the interval $(0, \infty)$ by $f(x) = \ln x + \int_0^x \sqrt{1 + \sin t} dt$. Then which of the following statement(s) is (are) true?
- (A) $f''(x)$ exists for all $x \in (0, \infty)$
 (B) $f'(x)$ exists for all $x \in (0, \infty)$ and f' is continuous on $(0, \infty)$, but not differentiable on $(0, \infty)$
 (C) there exists $\alpha > 1$ such that $|f'(x)| < |f(x)|$ for all $x \in (\alpha, \infty)$
 (D) there exists $\beta > 0$ such that $|f(x)| + |f'(x)| \leq \beta$ for all $x \in (0, \infty)$

Sol. (B), (C)

$$f'(x) = \frac{1}{x} + \sqrt{1 + \sin x}$$

$$f'(x) \text{ is not differentiable at } \sin x = -1 \text{ or } x = 2n\pi - \frac{\pi}{2}, n \in \mathbb{N}$$

$$\text{In } x \in (1, \infty) \quad f(x) > 0, f'(x) > 0$$

$$\begin{aligned} & \text{Consider } f(x) - f'(x) \\ &= \ln x + \int_0^x \sqrt{1 + \sin t} \, dt - \frac{1}{x} - \sqrt{1 + \sin x} \\ &= \left(\int_0^x \sqrt{1 + \sin t} \, dt - \sqrt{1 + \sin x} \right) + \ln x - \frac{1}{x} \end{aligned}$$

$$\text{Consider } g(x) = \int_0^x \sqrt{1 + \sin t} \, dt - \sqrt{1 + \sin x}$$

It can be proved that $g(x) \geq 2\sqrt{2} - \sqrt{10} \quad \forall x \in (0, \infty)$

Now there exists some $\alpha > 1$ such that $\frac{1}{x} - \ln x \leq 2\sqrt{2} - \sqrt{10}$ for all $x \in (\alpha, \infty)$ as $\frac{1}{x} - \ln x$ is strictly decreasing function.

$$\Rightarrow g(x) \geq \frac{1}{x} - \ln x.$$

SECTION – III (Paragraph Type)

This section contains **2 paragraphs**. Based upon the first paragraph 2 multiple choice questions and based upon the second paragraph **3 multiple choice questions** have to be answered. Each of these questions has four choices A), B), C) and D) out of **WHICH ONLY ONE CORRECT**.

Paragraph for Questions 42 to 43

The circle $x^2 + y^2 - 8x = 0$ and hyperbola $\frac{x^2}{9} - \frac{y^2}{4} = 1$ intersect at the points A and B.

42. Equation of a common tangent with positive slope to the circle as well as to the hyperbola is
- (A) $2x - \sqrt{5}y - 20 = 0$ (B) $2x - \sqrt{5}y + 4 = 0$
 (C) $3x - 4y + 8 = 0$ (D) $4x - 3y + 4 = 0$

Sol. (B)

A tangent to $\frac{x^2}{9} - \frac{y^2}{4} = 1$ is $y = mx + \sqrt{9m^2 - 4}$, $m > 0$

It is tangent to $x^2 + y^2 - 8x = 0$

$$\therefore \frac{4m + \sqrt{9m^2 - 4}}{\sqrt{1 + m^2}} = 4$$

$$\Rightarrow 495m^4 + 104m^2 - 400 = 0$$

$$\Rightarrow m^2 = \frac{4}{5} \text{ or } m = \frac{2}{\sqrt{5}}$$

$$\therefore \text{the tangent is } y = \frac{2}{\sqrt{5}}m + \frac{4}{\sqrt{5}}$$

$$\Rightarrow 2x - \sqrt{5}y + 4 = 0.$$

43. Equation of the circle with AB as its diameter is
- (A) $x^2 + y^2 - 12x + 24 = 0$ (B) $x^2 + y^2 + 12x + 24 = 0$
 (C) $x^2 + y^2 + 24x - 12 = 0$ (D) $x^2 + y^2 - 24x - 12 = 0$

Sol. (A)A point on hyperbola is $(3\sec\theta, 2\tan\theta)$ It lies on the circle, so $9\sec^2\theta + 4\tan^2\theta - 24\sec\theta = 0$

$$\Rightarrow 13\sec^2\theta - 24\sec\theta - 4 = 0 \Rightarrow \sec\theta = 2, -\frac{2}{13}$$

$$\therefore \sec\theta = 2 \Rightarrow \tan\theta = \sqrt{3}.$$

The point of intersection are $A(6, 2\sqrt{3})$ and $B(6, -2\sqrt{3})$ \therefore The circle with AB as diameter is

$$(x-6)^2 + y^2 = (2\sqrt{3})^2 \Rightarrow x^2 + y^2 - 12x + 24 = 0.$$

Paragraph for Questions 44 to 46Let p be an odd prime number and T_p be the following set of 2×2 matrices :

$$T_p = \left\{ A = \begin{bmatrix} a & b \\ c & a \end{bmatrix} : a, b, c \in \{0, 1, \dots, p-1\} \right\}$$

44. The number of A in T_p such that A is either symmetric or skew-symmetric or both, and $\det(A)$ divisible by p is

(A) $(p-1)^2$

(B) $2(p-1)$

(C) $(p-1)^2 + 1$

(D) $2p-1$

Sol. (D)We must have $a^2 - b^2 = kp$

$\Rightarrow (a+b)(a-b) = kp$

 \Rightarrow either $a-b=0$ or $a+b$ is a multiple of p when $a=b$; number of matrices is p and when $a+b = \text{multiple of } p \Rightarrow a, b$ has $p-1$

\therefore Total number of matrices = $p + p - 1$

$= 2p - 1.$

45. The number of A in T_p such that the trace of A is not divisible by p but $\det(A)$ is divisible by p is
[Note: The trace of a matrix is the sum of its diagonal entries.]

(A) $(p-1)(p^2 - p + 1)$

(B) $p^3 - (p-1)^2$

(C) $(p-1)^2$

(D) $(p-1)(p^2 - 2)$

Ans. (C)46. The number of A in T_p such that $\det(A)$ is not divisible by p is

(A) $2p^2$

(B) $p^3 - 5p$

(C) $p^3 - 3p$

(D) $p^3 - p^2$

Ans. (D)

SECTION – IV (Integer Type)

This section contains **TEN** questions. The answer to each question is a single digit integer ranging from 0 to 9. The correct digit below the question number in the **ORS** is to be bubbled.

47. Let S_k , $k = 1, 2, \dots, 100$, denote the sum of the infinite geometric series whose first term is $\frac{k-1}{k!}$ and the common ratio is $\frac{1}{k}$. Then the value of $\frac{100^2}{100!} + \sum_{k=1}^{100} |(k^2 - 3k + 1)S_k|$ is

Sol. (3)

$$\begin{aligned} S_k &= \frac{\frac{k-1}{k!}}{1 - \frac{1}{k}} = \frac{1}{(k-1)!} \\ \sum_{k=2}^{100} |(k^2 - 3k + 1)S_k| &= \sum_{k=2}^{100} \left| \frac{k^2 - 3k + 1}{(k-1)!} \right| \\ &= \sum_{k=2}^{100} \left| \frac{(k-1)^2 - k}{(k-1)!} \right| \\ &= \sum_{k=2}^{100} \left| \frac{k-1}{(k-2)!} - \frac{k}{(k-1)!} \right| \\ &= \left| \frac{2}{1!} - \frac{3}{2!} \right| + \left| \frac{3}{2!} - \frac{4}{3!} \right| + \dots \\ &= \frac{2}{1!} - \frac{1}{0!} + \frac{2}{1!} - \frac{3}{2!} + \frac{3}{2!} - \frac{4}{3!} + \dots + \frac{99}{98!} - \frac{100}{99!} \\ &= 3 - \frac{100}{99!} \end{aligned}$$

48. The number of all possible values of θ , where $0 < \theta < \pi$, for which the system of equations
- $$\begin{aligned} (y+z) \cos 3\theta &= (xyz) \sin 3\theta \\ x \sin 3\theta &= \frac{2 \cos 3\theta}{y} + \frac{2 \sin 3\theta}{z} \end{aligned}$$
- $(xyz) \sin 3\theta = (y+2z) \cos 3\theta + y \sin 3\theta$
have a solution (x_0, y_0, z_0) with $y_0 z_0 \neq 0$, is

Sol. (3)

$$\begin{aligned} (y+z) \cos 3\theta - (xyz) \sin 3\theta &= 0 && \dots (1) \\ xyz \sin 3\theta &= (2 \cos 3\theta) z + (2 \sin 3\theta) y && \dots (2) \\ \therefore (y+z) \cos 3\theta &= (2 \cos 3\theta) z + (2 \sin 3\theta) y = (y+2z) \cos 3\theta + y \sin 3\theta \\ y(\cos 3\theta - 2 \sin 3\theta) &= z \cos 3\theta \text{ and} \\ y(\sin 3\theta - \cos 3\theta) &= 0 \Rightarrow \sin 3\theta - \cos 3\theta = 0 \Rightarrow \sin 3\theta = \cos 3\theta \\ \therefore 3\theta &= n\pi + \pi/4 \end{aligned}$$

49. Let f be a real-valued differentiable function on \mathbb{R} (the set of all real numbers) such that $f(1) = 1$. If the y -intercept of the tangent at any point $P(x, y)$ on the curve $y = f(x)$ is equal to the cube of the abscissa of P , then the value of $f(-3)$ is equal to

Sol. (9)

$$y - y_1 = m(x - x_1)$$

Put $x = 0$, to get y intercept

$$y_1 - mx_1 = x_1^3$$

$$y_1 - x_1 \frac{dy}{dx} = x_1^3$$

$$x \frac{dy}{dx} - y = -x^3$$

$$\frac{dy}{dx} - \frac{y}{x} = -x^2$$

$$e^{\int -\frac{1}{x} dx} = e^{-\ln x} = \frac{1}{x}$$

$$y \times \frac{1}{x} = \int -x^2 \times \frac{1}{x} dx$$

$$\frac{y}{x} = -\int x dx \Rightarrow \frac{y}{x} = -\frac{x^2}{2} + c$$

$$\Rightarrow f(x) = -\frac{x^3}{2} + \frac{3}{2}x \therefore f(-3) = 9.$$

50. The number of values of θ in the interval $\left(-\frac{\pi}{2}, \frac{\pi}{2}\right)$ such that $\theta \neq \frac{n\pi}{5}$ for $n = 0, \pm 1, \pm 2$ and $\tan \theta = \cot 5\theta$ as well as $\sin 2\theta = \cos 4\theta$ is

Sol. (3)

$$\tan \theta = \cot 5\theta$$

$$\Rightarrow \cos 6\theta = 0$$

$$4\cos^3 2\theta - 3\cos 2\theta = 0$$

$$\Rightarrow \cos 2\theta = 0 \text{ or } \pm \frac{\sqrt{3}}{2}$$

$$\sin 2\theta = \cos 4\theta$$

$$\Rightarrow 2\sin^2 2\theta + \sin 2\theta - 1 = 0$$

$$2\sin^2 2\theta + 2\sin 2\theta - \sin 2\theta - 1 = 0$$

$$\sin 2\theta = -1 \text{ or } \sin 2\theta = \frac{1}{2}$$

$$\cos 2\theta = 0 \text{ and } \sin 2\theta = -1$$

$$\Rightarrow 2\theta = -\frac{\pi}{2} \Rightarrow \theta = -\frac{\pi}{4}$$

$$\cos 2\theta = \pm \frac{\sqrt{3}}{2}, \sin 2\theta = \frac{1}{2}$$

$$\Rightarrow 2\theta = \frac{\pi}{6}, \frac{5\pi}{6} \Rightarrow \theta = \frac{\pi}{12}, \frac{5\pi}{12}$$

$$\therefore \theta = -\frac{\pi}{4}, \frac{\pi}{12}, \frac{5\pi}{12}$$

51. The maximum value of the expression $\frac{1}{\sin^2 \theta + 3\sin \theta \cos \theta + 5\cos^2 \theta}$ is

Sol. (2)

$$\frac{1}{4 \cos^2 \theta + 1 + \frac{3}{2} \sin 2\theta}$$

$$\Rightarrow \frac{1}{2[1 + \cos 2\theta] + 1 + \frac{3}{2} \sin 2\theta}$$

lies between $\frac{1}{2}$ to $\frac{11}{2}$

\therefore maximum value is 2.

Minimum value of $1 + 4 \cos^2 \theta + 3 \sin \theta \cos \theta$

$$1 + \frac{4(1 + \cos 2\theta)}{2} + \frac{3}{2} \sin 2\theta$$

$$= 1 + 2 + 2 \cos 2\theta + \frac{3}{2} \sin 2\theta$$

$$= 3 + 2 \cos 2\theta + \frac{3}{2} \sin 2\theta$$

$$\therefore = 3 - \sqrt{4 + \frac{9}{4}} = 3 - \frac{5}{2} = \frac{1}{2}$$

So maximum value of $\frac{1}{4 \cos^2 \theta + 1 + \frac{3}{2} \sin 2\theta}$ is 2.

52. If \vec{a} and \vec{b} are vectors in space given by $\vec{a} = \frac{\hat{i} - 2\hat{j}}{\sqrt{5}}$ and $\vec{b} = \frac{2\hat{i} + \hat{j} + 3\hat{k}}{\sqrt{14}}$, then the value of $(2\vec{a} + \vec{b}) \cdot [(\vec{a} \times \vec{b}) \times (\vec{a} - 2\vec{b})]$ is

Sol. (5)

$$E = (2\vec{a} + \vec{b}) \cdot [2|\vec{b}|^2 \vec{a} - 2(\vec{a} \cdot \vec{b})\vec{b} - (\vec{a} \cdot \vec{b})\vec{a} + |\vec{a}|^2 \vec{b}]$$

$$\vec{a} \cdot \vec{b} = \frac{2-2}{\sqrt{70}} = 0$$

$$|\vec{a}| = 1$$

$$|\vec{b}| = 1$$

$$\vec{a} \cdot \vec{b} = 0$$

$$E = (2\vec{a} + \vec{b}) \cdot [2|\vec{b}|^2 \vec{a} + |\vec{a}|^2 \vec{b}]$$

$$= 4|\vec{a}|^2 |\vec{b}|^2 + |\vec{a}|^2 (\vec{a} \cdot \vec{b}) + 2|\vec{b}|^2 (\vec{b} \cdot \vec{a}) + |\vec{a}|^2 |\vec{b}|^2$$

$$= 5|\vec{a}|^2 |\vec{b}|^2 = 5$$

53. The line $2x + y = 1$ is tangent to the hyperbola $\frac{x^2}{a^2} - \frac{y^2}{b^2} = 1$. If this line passes through the point of intersection of the nearest directrix and the x-axis, then the eccentricity of the hyperbola is

Sol. (2)

Substituting $\left(\frac{a}{e}, 0\right)$ in $y = -2x + 1$

$$0 = -\frac{2a}{e} + 1$$

$$\frac{2a}{e} = 1$$

$$a = \frac{e}{2}$$

$$\text{Also, } 1 = \sqrt{a^2 m^2 - b^2}$$

$$1 = a^2 m^2 - b^2$$

$$1 = 4a^2 - b^2$$

$$1 = \frac{4e^2}{4} - b^2$$

$$b^2 = e^2 - 1.$$

$$\text{Also, } b^2 = a^2 (e^2 - 1)$$

$$\therefore a = 1, e = 2$$

54. If the distance between the plane $Ax - 2y + z = d$ and the plane containing the lines $\frac{x-1}{2} = \frac{y-2}{3} = \frac{z-3}{4}$ and $\frac{x-2}{3} = \frac{y-3}{4} = \frac{z-4}{5}$ is $\sqrt{6}$, then $|d|$ is

Sol. (6)

$$2l + 3m + 4n = 0$$

$$3l + 4m + 5n = 0$$

$$\frac{l}{-1} = \frac{m}{2} = \frac{n}{-1}$$

Equation of plane will be

$$a(x-1) + b(y-2) + c(z-3) = 0$$

$$-1(x-1) + 2(y-2) - 1(z-3) = 0$$

$$-x + 1 + 2y - 4 - z + 3 = 0$$

$$-x + 2y - z = 0$$

$$x - 2y + z = 0$$

$$\frac{|d|}{\sqrt{6}} = \sqrt{6}$$

$$d = 6.$$

55. For any real number x , let $[x]$ denote the largest integer less than or equal to x . Let f be a real valued function defined on the interval $[-10, 10]$ by

$$f(x) = \begin{cases} x - [x] & \text{if } [x] \text{ is odd} \\ 1 + [x] - x & \text{if } [x] \text{ is even} \end{cases}$$

Then the value of $\frac{\pi^2}{10} \int_{-10}^{10} f(x) \cos \pi x \, dx$ is

Sol. (4)

$$f(x) = \begin{cases} x - 1, & 1 \leq x < 2 \\ 1 - x, & 0 \leq x < 1 \end{cases}$$

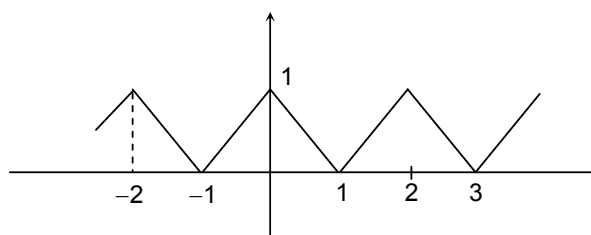

$f(x)$ is periodic with period 2

$$\begin{aligned} \therefore I &= \int_{-10}^{10} f(x) \cos \pi x \, dx \\ &= 2 \int_0^{10} f(x) \cos \pi x \, dx = 2 \times 5 \int_0^2 f(x) \cos \pi x \, dx \\ &= 10 \left[\int_0^1 (1-x) \cos \pi x \, dx + \int_1^2 (x-1) \cos \pi x \, dx \right] = 10(I_1 + I_2) \\ I_2 &= \int_1^2 (x-1) \cos \pi x \, dx \quad \text{put } x-1 = t \\ &= - \int_0^1 t \cos \pi t \, dt \\ I_1 &= \int_0^1 (1-x) \cos \pi x \, dx = - \int_0^1 x \cos(\pi x) \, dx \\ \therefore I &= 10 \left[-2 \int_0^1 x \cos \pi x \, dx \right] \\ &= -20 \left[x \frac{\sin \pi x}{\pi} + \frac{\cos \pi x}{\pi^2} \right]_0^1 \\ &= -20 \left[-\frac{1}{\pi^2} - \frac{1}{\pi^2} \right] = \frac{40}{\pi^2} \quad \therefore \frac{\pi^2}{10} I = 4 \end{aligned}$$

56. Let ω be the complex number $\cos \frac{2\pi}{3} + i \sin \frac{2\pi}{3}$. Then the number of distinct complex numbers z satisfying

$$\begin{vmatrix} z+1 & \omega & \omega^2 \\ \omega & z+\omega^2 & 1 \\ \omega^2 & 1 & z+\omega \end{vmatrix} = 0 \text{ is equal to}$$

Sol. (1)

$$\begin{aligned} \omega &= e^{i2\pi/3} \\ \begin{vmatrix} z+1 & \omega & \omega^2 \\ \omega & z+\omega^2 & 1 \\ \omega^2 & 1 & z+\omega \end{vmatrix} &= 0 \end{aligned}$$

$$\begin{vmatrix} 1 & \omega & \omega^2 \\ z & z+\omega^2 & 1 \\ 1 & 1 & z+\omega \end{vmatrix} = 0$$

$$\Rightarrow z[(z+\omega^2)(z+\omega) - 1 - \omega(z+\omega-1) + \omega^2(1-z-\omega^2)] = 0$$

$$\Rightarrow z^3 = 0$$

$\Rightarrow z = 0$ is only solution.

PART - III: PHYSICS

SECTION – I (Single Correct Choice Type)

This Section contains **8 multiple choice questions**. Each question has four choices A), B), C) and D) out of which **ONLY ONE** is correct.

57. Incandescent bulbs are designed by keeping in mind that the resistance of their filament increases with the increase in temperature. If at room temperature, 100 W, 60 W and 40 W bulbs have filament resistances R_{100} , R_{60} and R_{40} , respectively, the relation between these resistances is
- A) $\frac{1}{R_{100}} = \frac{1}{R_{40}} + \frac{1}{R_{60}}$ B) $R_{100} = R_{40} + R_{60}$
- C) $R_{100} > R_{60} > R_{40}$ D) $\frac{1}{R_{100}} > \frac{1}{R_{60}} > \frac{1}{R_{40}}$

Sol. (D)

Power $\propto 1/R$

58. To Verify Ohm's law, a student is provided with a test resistor R_T , a high resistance R_1 , a small resistance R_2 , two identical galvanometers G_1 and G_2 , and a variable voltage source V . The correct circuit to carry out the experiment is

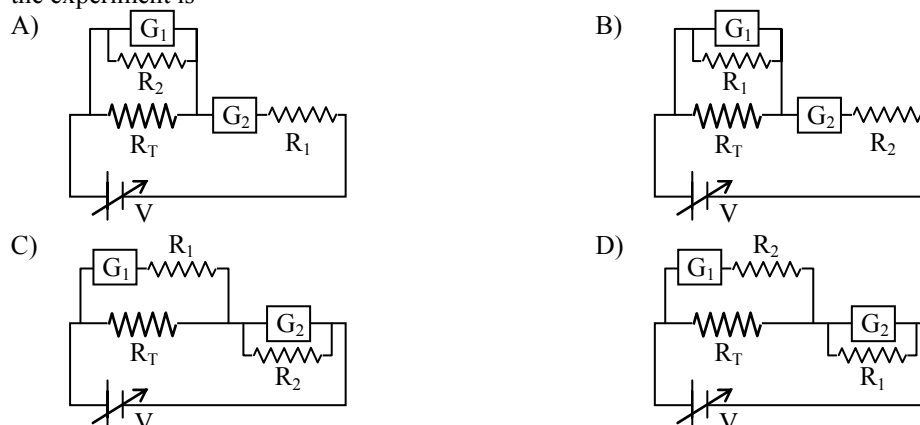

Sol. (C)

G_1 is acting as voltmeter and G_2 is acting as ammeter.

59. An AC voltage source of variable angular frequency ω and fixed amplitude V_0 is connected in series with a capacitance C and an electric bulb of resistance R (inductance zero). When ω is increased
- A) the bulb glows dimmer B) the bulb glows brighter
- C) total impedance of the circuit is unchanged D) total impedance of the circuit increases

Sol. (B)

$$\text{Impedance } Z = \sqrt{\frac{1}{(\omega C)^2} + R^2}$$

as ω increases, Z decreases.
Hence bulb will glow brighter

60. A thin flexible wire of length L is connected to two adjacent fixed points and carries a current I in the clockwise direction, as shown in the figure. When the system is put in a uniform magnetic field of strength B going into the plane of the paper, the wire takes the shape of a circle. The tension in the wire is

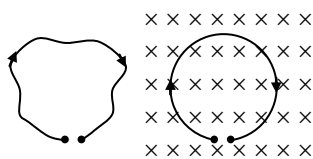

- A) IBL
 B) $\frac{IBL}{\pi}$
 C) $\frac{IBL}{2\pi}$
 D) $\frac{IBL}{4\pi}$

Sol. (C)

$$2T \sin \frac{d\theta}{2} = BiRd\theta$$

$$Td\theta = BiRd\theta \quad (\text{for } \theta \text{ small})$$

$$T = BiR = \frac{BiL}{2\pi}$$

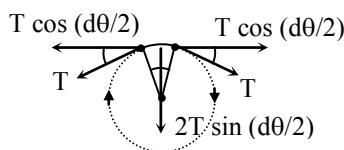

61. A block of mass m is on an inclined plane of angle θ . The coefficient of friction between the block and the plane is μ and $\tan \theta > \mu$. The block is held stationary by applying a force P parallel to the plane. The direction of force pointing up the plane is taken to be positive. As P is varied from $P_1 = mg(\sin\theta - \mu \cos\theta)$ to $P_2 = mg(\sin\theta + \mu \cos\theta)$, the frictional force f versus P graph will look like

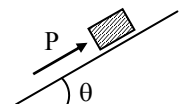

- A)
 B)
 C)
 D)

Sol. (A)

Initially the frictional force is upwards as P increases frictional force decreases.

62. A thin uniform annular disc (see figure) of mass M has outer radius $4R$ and inner radius $3R$. The work required to take a unit mass from point P on its axis to infinity is

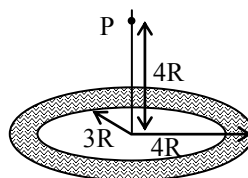

- A) $\frac{2GM}{7R}(4\sqrt{2}-5)$
 B) $-\frac{2GM}{7R}(4\sqrt{2}-5)$
 C) $\frac{GM}{4R}$
 B) $\frac{2GM}{5R}(\sqrt{2}-1)$

Sol. (A)

$$V = - \int_{3R}^{4R} \frac{\sigma 2\pi r dr G}{\sqrt{r^2 + 16R^2}}$$

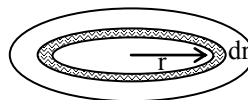

63. Consider a thin square sheet of side L and thickness t, made of a material of resistivity ρ . The resistance between two opposite faces, shown by the shaded areas in the figure is

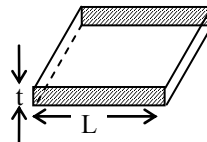

- A) directly proportional to L
 C) independent of L
 B) directly proportional to t
 D) independent of t

Sol. (C)

$$R = \frac{\rho L}{Lt}$$

64. A real gas behaves like an ideal gas if its
 A) pressure and temperature are both high
 B) pressure and temperature are both low
 C) pressure is high and temperature is low
 D) pressure is low and temperature is high

Sol. (D)

SECTION – II (Multiple Correct Choice Type)

This section contains **5 multiple choice questions**. Each question has four choices A), B), C) and D) out of which **ONE OR MORE** may be correct.

65. A point mass of 1 kg collides elastically with a stationary point mass of 5 kg. After their collision, the 1 kg mass reverses its direction and moves with a speed of 2 ms^{-1} . Which of the following statement(s) is (are) correct for the system of these two masses?
 A) Total momentum of the system is 3 kg ms^{-1}
 B) Momentum of 5 kg mass after collision is 4 kg ms^{-1}
 C) Kinetic energy of the centre of mass is 0.75 J
 D) Total kinetic energy of the system is 4 J

Sol. (A, C)

By conservation of linear momentum

$$u = 5v - 2 \quad \dots (i)$$

By Newton's experimental law of collision

$$u = v + 2 \quad \dots (ii)$$

using (i) and (ii) we have

$$v = 1 \text{ m/s and } u = 3 \text{ m/s}$$

$$\text{Kinetic energy of the centre of mass} = \frac{1}{2} m_{\text{system}} v_{\text{cm}}^2 = 0.75 \text{ J}$$

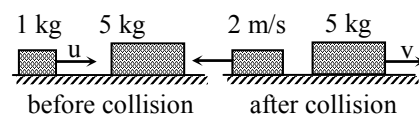

66. One mole of an ideal gas in initial state A undergoes a cyclic process ABCA, as shown in the figure. Its pressure at A is P_0 . Choose the correct option(s) from the following

- A) Internal energies at A and B are the same
 B) Work done by the gas in process AB is $P_0V_0 \ln 4$
 C) Pressure at C is $\frac{P_0}{4}$
 D) Temperature at C is $\frac{T_0}{4}$

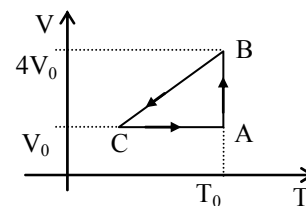

Sol. (A, B)
 Process AB is isothermal process

67. A student uses a simple pendulum of exactly 1m length to determine g , the acceleration due to gravity. He uses a stop watch with the least count of 1 sec for this and records 40 seconds for 20 oscillations. For this observation, which of the following statement(s) is (are) true?

- A) Error ΔT in measuring T , the time period, is 0.05 seconds
 B) Error ΔT in measuring T , the time period, is 1 second
 C) Percentage error in the determination of g is 5%
 D) Percentage error in the determination of g is 2.5%

Sol. (A, C)

$$\frac{\Delta T}{T} = \frac{\Delta t}{t} = \frac{1}{40}$$

$$\Delta T = 0.05 \text{ sec}$$

$$g = \frac{4\pi^2 L n^2}{t^2}$$

$$\frac{\Delta g}{g} = \frac{2\Delta t}{t}$$

$$\Rightarrow \% \text{ error} = \frac{2\Delta t}{t} \times 100 = 5\%$$

68. A few electric field lines for a system of two charges Q_1 and Q_2 fixed at two different points on the x-axis are shown in the figure. These lines suggest that

- A) $|Q_1| > |Q_2|$
 B) $|Q_1| < |Q_2|$
 C) at a finite distance to the left of Q_1 the electric field is zero
 D) at a finite distance to the right of Q_2 the electric field is zero

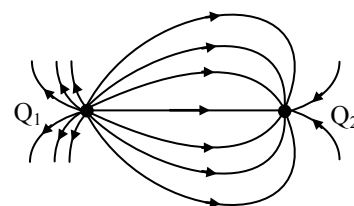

Sol. (A, D)

No. of electric field lines of forces emerging from Q_1 are larger than terminating at Q_2

69. A ray OP of monochromatic light is incident on the face AB of prism ABCD near vertex B at an incident angle of 60° (see figure). If the refractive index of the material of the prism is $\sqrt{3}$, which of the following is (are) correct?
- A) The ray gets totally internally reflected at face CD
 - B) The ray comes out through face AD
 - C) The angle between the incident ray and the emergent ray is 90°
 - D) The angle between the incident ray and the emergent ray is 120°

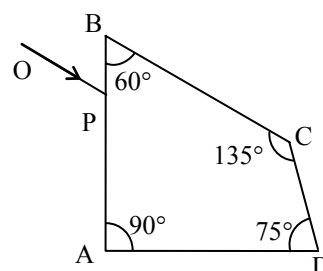

Sol. (A, B, C)

Using snell's law

$$\sin^{-1} \frac{1}{\sqrt{3}} < \sin^{-1} \frac{1}{\sqrt{2}}$$

Net deviation is 90°

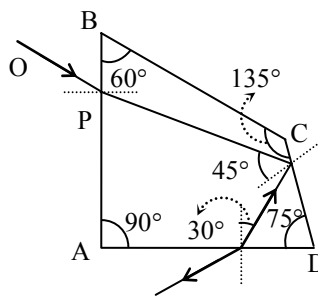

SECTION –III (Paragraph Type)

This section contains **2 paragraphs**. Based upon the first paragraph 2 multiple choice questions and based upon the second paragraph **3 multiple choice questions** have to be answered. Each of these questions has four choices A), B), C) and D) out of **WHICH ONLY ONE CORRECT**.

Paragraph for Questions 70 to 71

Electrical resistance of certain materials, known as superconductors, changes abruptly from a nonzero value to zero as their temperature is lowered below a critical temperature $T_c(0)$. An interesting property of superconductors is that their critical temperature becomes smaller than $T_c(0)$ if they are placed in a magnetic field, i.e., the critical temperature $T_c(B)$ is a function of the magnetic field strength B. The dependence of $T_c(B)$ on B is shown in the figure.

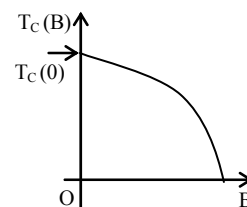

70. In the graphs below, the resistance R of a superconductor is shown as a function of its temperature T for two different magnetic fields B_1 (solid line) and B_2 (dashed line). If B_2 is larger than B_1 which of the following graphs shows the correct variation of R with T in these fields?

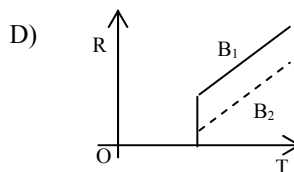
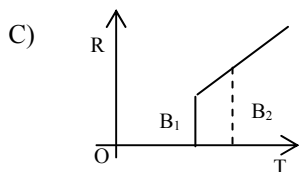
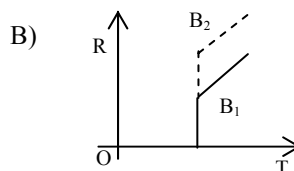
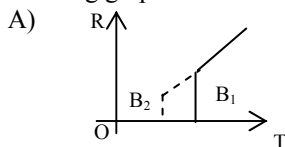

Sol. (A)

Larger the magnetic field smaller the critical temperature.

71. A superconductor has $T_c(0) = 100$ K. When a magnetic field of 7.5 Tesla is applied, its T_c decreases to 75 K. For this material one can definitely say that when

- A) $B = 5$ Tesla, $T_c(B) = 80$ K
 B) $B = 5$ Tesla, $75 \text{ K} < T_c(B) < 100$ K
 C) $B = 10$ Tesla, $75 \text{ K} < T_c < 100$ K
 D) $B = 10$ Tesla, $T_c = 70$ K

Sol. (B)

Paragraph for Questions 72 to 74

When a particle of mass m moves on the x -axis in a potential of the form $V(x) = kx^2$ it performs simple harmonic motion.

The corresponding time period is proportional to $\sqrt{\frac{m}{k}}$, as can

be seen easily using dimensional analysis. However, the motion of a particle can be periodic even when its potential energy increases on both sides of $x = 0$ in a way different from kx^2 and its total energy is such that the particle does not escape to infinity. Consider a particle of mass m moving on the x -axis. Its potential energy is $V(x) = \alpha x^4$ ($\alpha > 0$) for $|x|$ near the origin and becomes a constant equal to V_0 for $|x| \geq X_0$ (see figure).

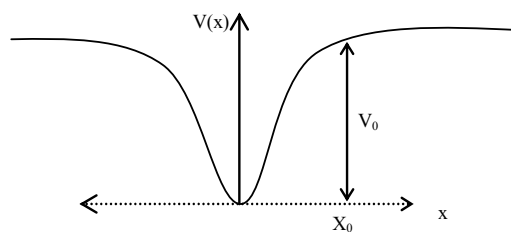

72. If the total energy of the particle is E , it will perform periodic motion only if

- A) $E < 0$
 B) $E > 0$
 C) $V_0 > E > 0$
 D) $E > V_0$

Sol. (C)

Energy must be less than V_0

73. For periodic motion of small amplitude A , the time period T of this particle is proportional to

- A) $A\sqrt{\frac{m}{\alpha}}$
 B) $\frac{1}{A}\sqrt{\frac{m}{\alpha}}$
 C) $A\sqrt{\frac{\alpha}{m}}$
 D) $A\sqrt{\frac{\alpha}{m}}$

Sol. (B)

$$[\alpha] = ML^{-2}T^{-2}$$

Only (B) option has dimension of time

Alternatively

$$\frac{1}{2}m\left(\frac{dx}{dt}\right)^2 + kx^4 = kA^4$$

$$\left(\frac{dx}{dt}\right)^2 = \frac{2k}{m}(A^4 - x^4)$$

$$4\sqrt{\frac{m}{2k}} \int_0^A \frac{dx}{\sqrt{A^4 - x^4}} = \int dt = T$$

$$4\sqrt{\frac{m}{2k}} \frac{1}{A} \int_0^1 \frac{du}{\sqrt{1-u^4}} = T \quad \text{Substitute } x = Au$$

74. The acceleration of this particle for $|x| > X_0$ is
- A) proportional to V_0 B) proportional to $\frac{V_0}{mX_0}$
- C) proportional to $\sqrt{\frac{V_0}{mX_0}}$ D) zero

Sol. (D)
As potential energy is constant for $|x| > X_0$, the force on the particle is zero hence acceleration is zero.

SECTION –IV (Integer Type)

This section contains **TEN** questions. The answer to each question is a single digit integer ranging from 0 to 9. The correct digit below the question number in the **ORS** is to be bubbled.

75. Gravitational acceleration on the surface of a planet is $\frac{\sqrt{6}}{11}g$, where g is the gravitational acceleration on the surface of the earth. The average mass density of the planet is $\frac{2}{3}$ times that of the earth. If the escape speed on the surface of the earth is taken to be 11 km s^{-1} , the escape speed on the surface of the planet in km s^{-1} will be

Sol. 3

$$\frac{g'}{g} = \frac{\sqrt{6}}{11}, \quad \frac{\rho'}{\rho} = \frac{2}{3}$$

Hence, $\frac{R'}{R} = \frac{3\sqrt{6}}{22}$

$$\frac{v'_{\text{esc}}}{v_{\text{esc}}} \propto \sqrt{\frac{R'^2 \rho'}{R^2 \rho}} = \frac{3}{11}$$

$v'_{\text{esc}} = 3 \text{ km/s}.$

76. A piece of ice (heat capacity = $2100 \text{ J kg}^{-1} \text{ } ^\circ\text{C}^{-1}$ and latent heat = $3.36 \times 10^5 \text{ J kg}^{-1}$) of mass m grams is at -5°C at atmospheric pressure. It is given 420 J of heat so that the ice starts melting. Finally when the ice-water mixture is in equilibrium, it is found that 1 gm of ice has melted. Assuming there is no other heat exchange in the process, the value of m is

Sol. 8

$$420 = (m \times 2100 \times 5 + 1 \times 3.36 \times 10^5) \times 10^{-3}$$

where m is in gm.

77. A stationary source is emitting sound at a fixed frequency f_0 , which is reflected by two cars approaching the source. The difference between the frequencies of sound reflected from the cars is 1.2% of f_0 . What is the difference in the speeds of the cars (in km per hour) to the nearest integer? The cars are moving at constant speeds much smaller than the speed of sound which is 330 m s^{-1} .

Sol. 7

$$f_{\text{app}} = f_0 \frac{c+v}{c-v}$$

$$df = \frac{2f_0 c}{(c-v)^2} dv$$

where c is speed of sound

$$df = \frac{1.2}{100} f_0$$

hence $dv \approx 7$ km/hr.

78. The focal length of a thin biconvex lens is 20 cm. When an object is moved from a distance of 25 cm in front of it to 50 cm, the magnification of its image changes from m_{25} to m_{50} . The ratio $\frac{m_{25}}{m_{50}}$ is

Sol. 6

$$m = \frac{f}{f+u}$$

79. An α -particle and a proton are accelerated from rest by a potential difference of 100 V. After this, their de Broglie wavelengths are λ_α and λ_p respectively. The ratio $\frac{\lambda_p}{\lambda_\alpha}$, to the nearest integer, is

Sol. 3

$$\frac{1}{2}mv^2 = qV$$

$$\lambda = \frac{h}{mv}$$

$$\lambda = \sqrt{8} \approx 3.$$

80. When two identical batteries of internal resistance 1Ω each are connected in series across a resistor R , the rate of heat produced in R is J_1 . When the same batteries are connected in parallel across R , the rate is J_2 . If $J_1 = 2.25 J_2$ then the value of R in Ω is

Sol. 4

$$J_1 = \left(\frac{2E}{R+2} \right)^2 R$$

$$J_2 = \left(\frac{E}{R+1/2} \right)^2 R \quad \text{since } J_1/J_2 = 2.25$$

$$R = 4 \Omega.$$

81. Two spherical bodies A (radius 6 cm) and B (radius 18 cm) are at temperature T_1 and T_2 , respectively. The maximum intensity in the emission spectrum of A is at 500 nm and in that of B is at 1500 nm. Considering them to be black bodies, what will be the ratio of the rate of total energy radiated by A to that of B?

Sol. 9

$$\lambda_m T = \text{constant}$$

$$\lambda_A T_A = \lambda_B T_B$$

$$\text{Rate of total energy radiated} \propto AT^4$$

82. When two progressive waves $y_1 = 4 \sin(2x - 6t)$ and $y_2 = 3 \sin\left(2x - 6t - \frac{\pi}{2}\right)$ are superimposed, the amplitude of the resultant wave is

Sol. 5

Two waves have phase difference $\pi/2$.

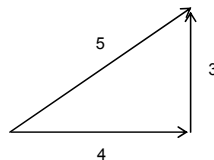

83. A 0.1 kg mass is suspended from a wire of negligible mass. The length of the wire is 1m and its cross-sectional area is $4.9 \times 10^{-7} \text{ m}^2$. If the mass is pulled a little in the vertically downward direction and released, it performs simple harmonic motion of angular frequency 140 rad s^{-1} . If the Young's modulus of the material of the wire is $n \times 10^9 \text{ Nm}^{-2}$, the value of n is

Sol. 4

$$\omega = \sqrt{\frac{YA}{mL}}$$

84. A binary star consists of two stars A (mass $2.2M_s$) and B (mass $11M_s$), where M_s is the mass of the sun. They are separated by distance d and are rotating about their centre of mass, which is stationary. The ratio of the total angular momentum of the binary star to the angular momentum of star B about the centre of mass is

Sol. 6

$$\frac{L_{\text{total}}}{L_B} = \frac{m_1 r_1^2}{m_2 r_2^2} + 1$$
